

interstuhl

Interstuhl
Büromöbel GmbH & Co. KG
Brühlstraße 21
D-72469 Meßstetten-Tieringen
Phone +49-7436-871-0
Fax +49-7436-871-110
info@interstuhl.de
www.interstuhl.de

Ident. - Nr. 00033743

Campos

Bedienungsanleitung
Operating instructions
Mode d'emploi
Gebruiksaanwijzing
Instrucciones de uso
Istruzioni d'uso



Montage
Assembly
Montage
Montage
Montaje
Montaggio

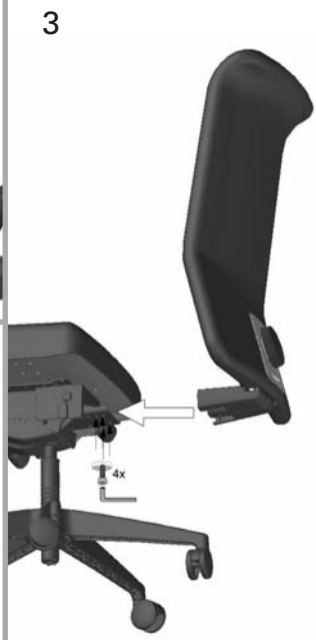
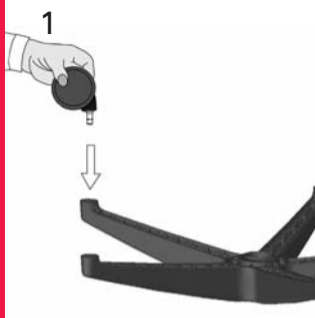

Montage
Assembly
Montage
Montage
Montaje
Montaggio

4

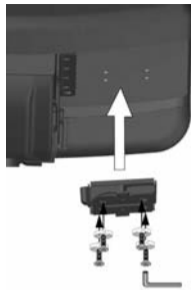

5

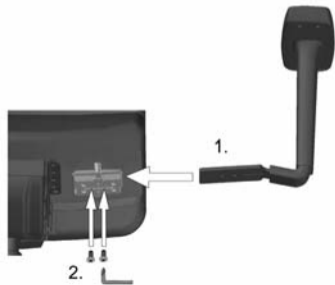



Sitzhöhenverstellung

Seat height adjustment

Réglage de la hauteur d' assise

Zithoogteverstelling

Regulación de altura del asiento

Regolazione altezza seduta





Synchronmechanik
Synchronous mechanism
Mécanisme synchrone
Synchroontechiek
Mecanismo sincronizado
Meccanismo syncro





Gewichtsregulierung
Weight adjustment
Réglage de tension
Gewichtsregeling
Regulación de peso
Regolazione peso



15C2



Lordosenstütze (Option)
Lumbar support (option)
Soutien lombaire (option)
Lendensteun (optie)
Apoyo lumbar (opción)
Supporto lombare (opzione)



17C2



Lordosenstütze (Option)
Lumbar support (option)
Soutien lombaire (option)
Lendensteun (optie)
Apoyo lumbar (opción)
Supporto lombare (opzione)





Rückenlehnen-Höhenverstellung
Back height adjustment
Dossier réglable en hauteur
Rugleuning in hoogte verstelbaar
Regulación de altura del respaldo
Regolazione altezza schienale





Sitztiefenverstellung (Option)

Seat depth adjustment (option)

Réglage la profondeur d' assise (option)

Zitdiepteverstelling (optie)

Regulación de la profundidad del asiento (opción)

Regolazione profondità seduta (opzione)





Sitzneigeverstellung (Option)

Seat inclination adjustment (option)

Réglage de l'inclinaison d' assise (option)

Zitneigverstelling (optie)

Regulación de la inclinación del asiento (opción)

Regolazione inclinazione seduta (opzione)





Höhenverstellung der Armlehnen

Height adjustable armrests

Accoudoirs réglables en hauteur

Hoogteverstelling van de armleggers

Regulación de la altura de los brazos

Regolazione altezza braccioli





Breitenverstellung der Armlehnen
Width adjustable armrests
Accoudoirs réglables en largeur
Breedteverstelling van de armleggers
Regulación del ancho de los brazos
Regolazione larghezza braccioli





4D Armlehnen
4D armrests
4D accoudoirs
4D armleggers
4D brazos
4D braccioli

Tiefenverstellung der Armauflage

Adjustable arm supports

Avant - bras réglable

Armleggeropdek in diepte verstelbaar

Superficie de apoyo de los brazos regulable en profundidad

Regolazione parte superiore braccioli





4D Armlehnen

4D armrests

4D accoudoirs

4D armleggers

4D brazos

4D braccioli

Armauflage schwenkbar

Swivel arm support

Avant - bras pivotants

Armleggeropdek zwenkbaar

Brazos retrotraibles

Parte superiore del bracciolo girevole

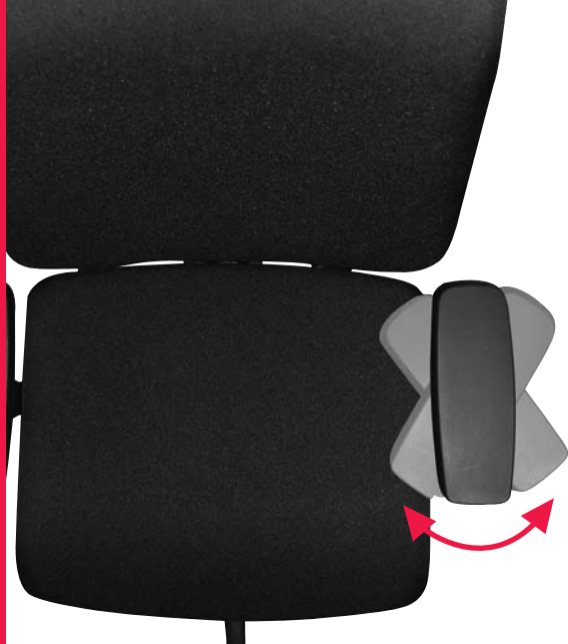

www.interstuhl.de

Interaktive Bedienungsanleitung
Interactive operating instructions
Mode d'emploi interactif
Interactieve gebruiksaanwijzing
Instrucciones de uso interactivo
Istruzioni d'uso interattive

Reinigungs- und Pflegehinweise
Care and maintenance
Conseils d'entretien et de nettoyage
Reinigings- en schoomaakinstructies
Indicaciones de Limpieza
Usa e manutenzione



Qualitätszertifikate

Quality certificates

Certificats de qualité

Kwaliteitscertificaten

Certificados de calidad

Certificati di Qualità

Der Hersteller haftet nicht für Schäden aus unsachgemäßem Gebrauch oder aus Nachlässigkeiten in der Wartung. Im Rahmen des GS-Zeichens werden Bürostühle mit einer Belastung, die 120 kg Körpergewicht entspricht, geprüft.

The manufacturer is not liable for damages due to improper use or negligence of maintenance. The GS-Certificate proves that office chairs are able to carry the body weight of 120 kilo gram.

Le fabricant n'est pas responsable de dommages résultant d'une utilisation non conforme du produit et de dommages résultant d'opérations de maintenance. Dans le cadre du Certificat GS, les sièges de bureau correspondent à une charge de 120 Kg.

De fabrikant is niet aansprakelijk voor schade die ontstaan door oneigenlijk gebruik of nalatigheid in het onderhoud. Conform het GS-certificaat (gecontroleerde veiligheid) worden kantoor-draaistoelen getest met een belasting die overeenkomt met 120 kg lichaamsgewicht.

El fabricante no se responsabiliza de posibles daños causados a raíz de un uso indebido del producto o de negligencias en el mantenimiento. El certificado GS demuestra que las sillas de oficina son capaces de aguantar un peso corporal de 120 Kg.

Il produttore non è responsabile per danni dovuti ad un uso improprio o a negligenza nella manutenzione della merce. Il certificato GS prova che le sedie per ufficio hanno una portata massima di peso corporeo pari a 120 Kg.

15C2



17C2



46C0/47C0 o. Abb.



56C0/57C0 o. Abb.



Campos Bürodrehstühle

Campos swivel chairs

Campos sièges de bureau pivotants

Campos draaistoelen

Campos sillas giratorias

Campos sedia girevole

Campos Besucherstühle

Campos visitors' chairs

Campos sièges de visiteur

Campos bezoekerstoelen

Campos sillas para de visitas

Campos seduta per visitatore