

Interstuhl  
Büromöbel GmbH & Co. KG  
Brühlstraße 21  
D-72469 Meßstetten-Tieringen  
Phone +49-7436-871-0  
Fax +49-7436-871-110  
Info@interstuhl.de  
www.interstuhl.de

Ident. - Nr. 00044840

Goal 172G/175G

Bedienungsanleitung  
Operating instructions  
Mode d'emploi  
Gebruiksaanwijzing  
Instrucciones de uso  
Istruzioni d'uso



interstuhl

Montage, Rollen u. Stuhlsäule  
Assembly, castors and chair column  
Montage, roulettes et vérin  
Montage, wielen en gasveer  
Montaje, ruedas y pistón de gas  
Montaggio, ruote colonna centrale con pistone a gas

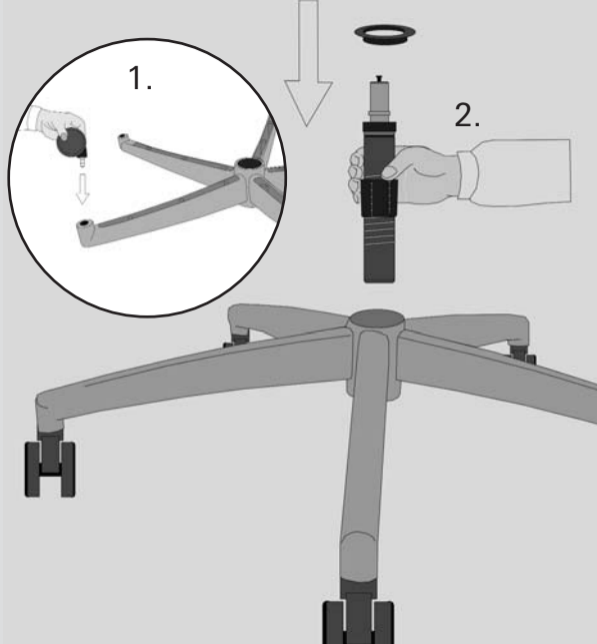

Montage, Rückenlehne  
Assembly, backrest  
Montage, dossier  
Montage, rugleuning  
Montaje, respaldo  
Montaggio, schienale

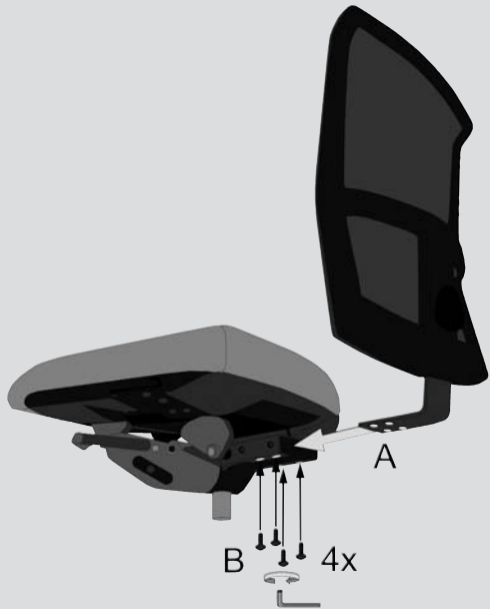

Montage, Armlehnen  
Assembly, armrests  
Montage, accoudoirs  
Montage, armleggers  
Montaje, brazos  
Montaggio, braccioli

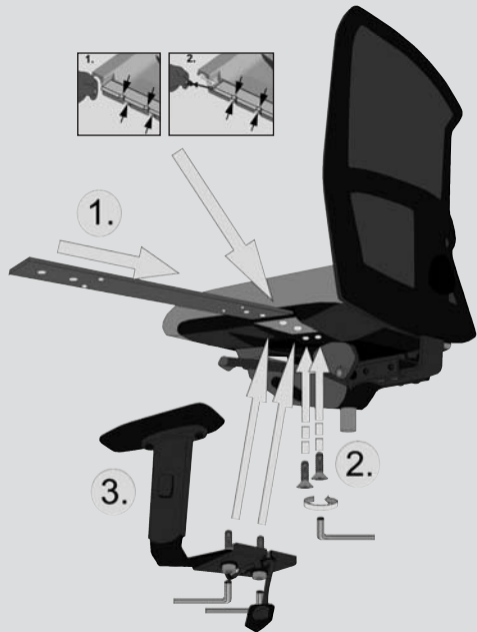



Sitzhöhenverstellung

Seat height adjustment

Réglage de la hauteur d' assise

Zithoogteverstelling

Regulación de altura del asiento

Regolazione altezza seduta





Synchronmechanik  
Synchronous mechanism  
Mécanisme synchrone  
Synchroontechiek  
Mecanismo sincronizado  
Meccanismo syncro





Gewichtsregulierung  
Weight adjustment  
Réglage de tension  
Gewichtsregeling  
Regulación de peso  
Regolazione peso





Rückenlehnen-Höhenverstellung

Back height adjustment

Dossier réglable en hauteur

Rugleuning in hoogte verstelbaar

Regulación de altura del respaldo

Regolazione altezza schienale





Lordosenstütze (Option)  
Lumbar support (option)  
Soutien lombaire (option)  
Lendensteun (optie)  
Apoyo lumbar (opción)  
Supporto lombare (opzione)





- Sitztieffenverstellung (Option)
- Seat depth adjustment (option)
- Réglage la profondeur d' assise (option)
- Zitdiepteverstelling (optie)
- Regulación de la profundidad del asiento (opción)
- Regolazione profondità seduta (opzione)





Sitzneigeverstellung (Option)

Seat inclination adjustment (option)

Réglage de l'inclinaison d'assise (option)

Zitneigverstelling (optie)

Regulación de la inclinación del asiento (opción)

Regolazione inclinazione seduta (opzione)



Höhenverstellung der Armlehnen  
Height adjustable armrests  
Accoudoirs réglables en hauteur  
Hoogteverstelling van de armleggers  
Regulación de la altura de los brazos  
Regolazione altezza braccioli





Breitenverstellung der Armlehnen

Width adjustable armrests

Accoudoirs réglables en largeur

Breedteverstelling van de armleggers

Regulación del ancho de los brazos

Regolazione larghezza braccioli





Tiefenverstellung der Armauflage

Depth adjustable armrest pads

Avant - bras réglable

Diepteverstelling van de armleggeropdekjes

Superficie de apoyo de los brazos regulable en profundidad

Regolazione parte superiore braccioli





Armauflage schwenkbar

Swivel arm support

Avant - bras pivotants

Armleggeropdek zwenkbaar

Brazos retrotraibles

Parte superiore del bracciolo girevole





Kopfstütze - Höhenverstellung  
Headrest - height adjustment  
Repose-tête - réglable en hauteur  
Hoofdsteen - hoogteverstelling  
Reposacabezas - regulación de altura  
Poggiatesta - regolazione altezza





Kopfstütze - Tiefenverstellung

Headrest - depth adjustment

Repose-tête - réglage de la profondeur

Hoofdsteen - diepteverstelling

Reposacabezas - regulación de la profundidad

Poggiatesta - regolazione profondità



Interaktive Bedienungsanleitung  
Interactive operating instructions  
Mode d'emploi interactif  
Interactieve gebruiksaanwijzing  
Instrucciones de uso interactivo  
Istruzioni d'uso interattive

Reinigungs- und Pflegehinweise  
Care and maintenance  
Conseils d'entretien et de nettoyage  
Reinigings- en schoomaakinstructies  
Indicaciones de Limpieza  
Uso e manutenzione

[www.interstuhl.de](http://www.interstuhl.de)



Qualitätszertifikate  
Quality certificates  
Certificats de qualité  
Kwaliteitscertificaten  
Certificados de calidad  
Certificati di Qualità

Der Hersteller haftet nicht für Schäden aus unsachgemäßem Gebrauch oder aus Nachlässigkeiten in der Wartung. Im Rahmen des GS-Zeichens werden Bürostühle mit einer Belastung, die 120 kg Körpergewicht entspricht, geprüft.

The manufacturer is not liable for damages due to improper use or negligence of maintenance. The GS-Certificate proves that office chairs are able to carry the body weight of 120 kilo gram.

Le fabricant n'est pas responsable de dommages résultant d'une utilisation non conforme du produit et de dommages résultant d'opérations de maintenance. Dans le cadre du Certificat GS, les sièges de bureau correspondent à une charge de 120 Kg.

De fabrikant is niet aansprakelijk voor schade die ontstaan door oneigenlijk gebruik of nalatigheid in het onderhoud. Conform het GS-certificaat (gecontroleerde veiligheid) worden kantoor-draaistoelen getest met een belasting die overeenkomt met 120 kg lichaamsgewicht.

El fabricante no se responsabiliza de posibles daños causados a raíz de un uso indebido del producto o de negligencias en el mantenimiento. El certificado GS demuestra que las sillas de oficina son capaces de aguantar un peso corporal de 120 Kg.

Il produttore non è responsabile per danni dovuti ad un uso improprio o a negligenza nella manutenzione della merce. Il certificato GS prova che le sedie per ufficio hanno una portata massima di peso corporeo pari a 120 Kg.

101G  
102G (o. Abb.)



151G  
152G (o. Abb.)



302G



322G



172G



175G



Goal Bürodrehstühle

Goal swivel chairs

Goal sièges de bureau pivotants

Goal draaistoelen

Goal sillas giratorias

Goal sedia girevole